

THIS DRAWING IS UNPUBLISHED. RELEASED FOR PUBLICATION, 19
 © COPYRIGHT 19 BY AMP INCORPORATED. ALL INTERNATIONAL RIGHTS RESERVED.

LOC	DIST	P	F	REVISIONS				
AF	50			ZONE	LTR	DESCRIPTION	DATE	APPD
					0	DRAWN	4/11/95	JR/JG

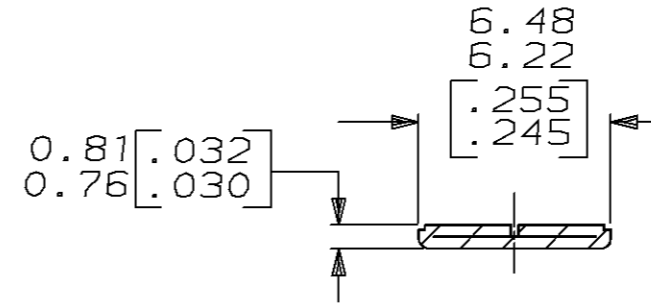

SECTION A-A

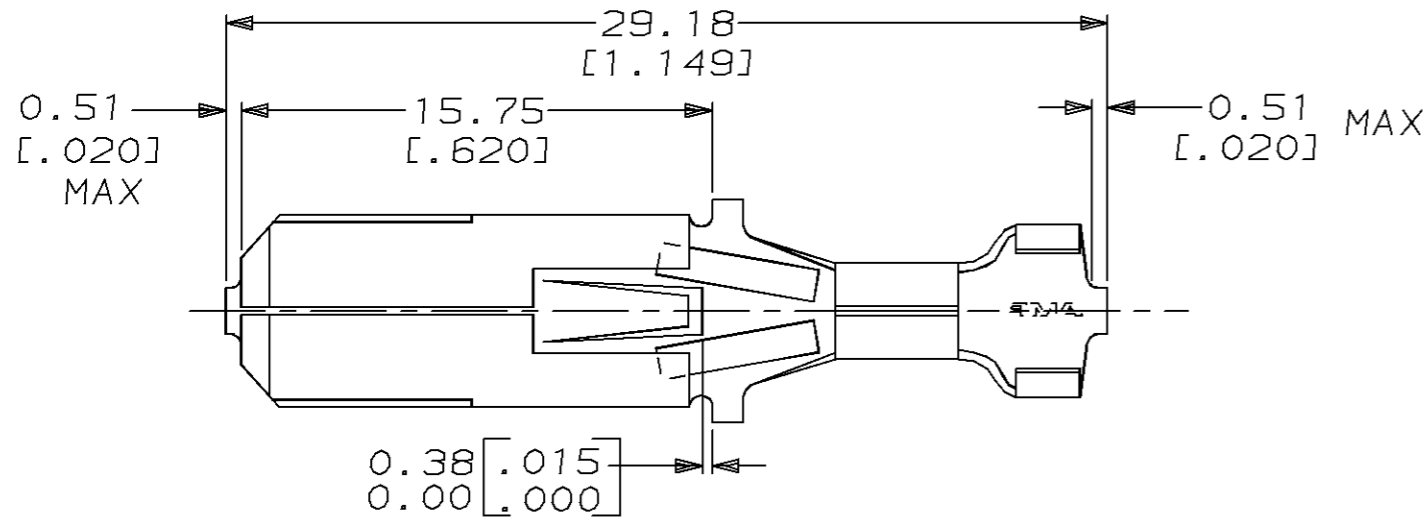
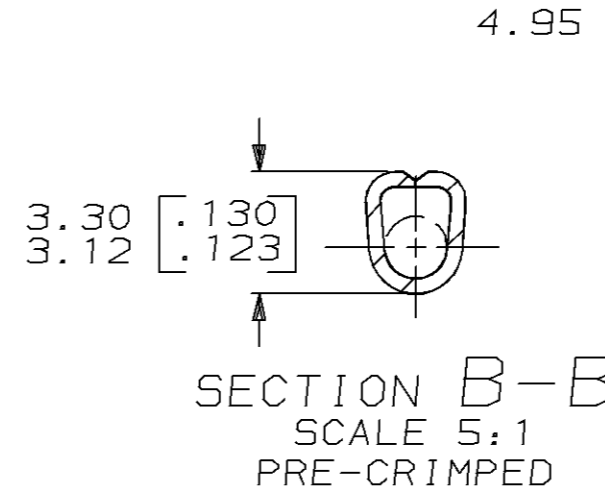
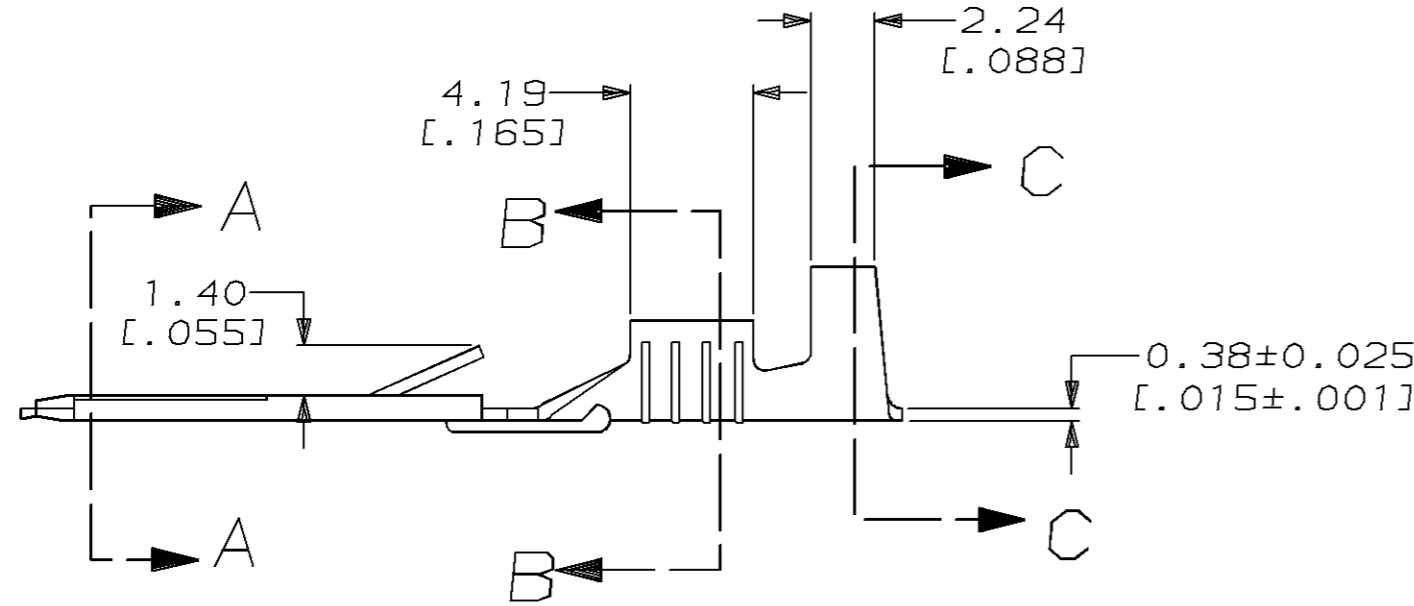

SECTION B-B
SCALE 5:1
PRE-CRIMPED

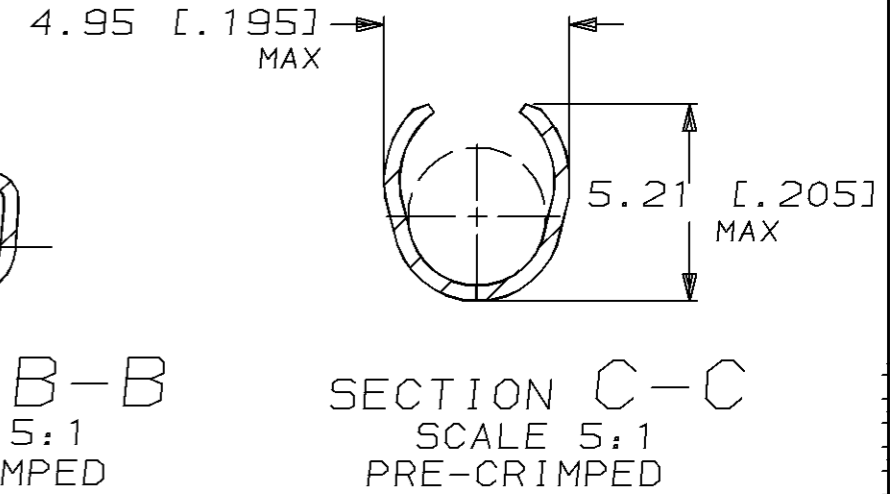

SECTION C-C
SCALE 5:1
PRE-CRIMPED

- 1 SUPPLIED IN LOOSE PIECE.
- 2 FOREIGN PRODUCTION ONLY.
- 3 WIRE BARREL ACCEPTS A [#18-#14] AWG.
- 4 INSULATION RANGE IS 3.05-4.06 DIA [.120-.160] DIA.

0.003048 [.000120] MIN SILVER	H02 BRASS	42241-3
0.002032 [.000080] MIN TIN	H02 BRASS	42241-2
NONE	H02 BRASS	42241-1
FINISH	MATERIAL	PART NO
DO NOT SCALE PRINT. UNLESS SPECIFIED DIMENSIONS IN mm [INCHES] TOLERANCES ON: 2 PLC DEC ± 0.38 [.015] 3 PLC DEC ± - ANGLES ± -	DR 4/11/95 JR RUTH CHK 4/11/95 MS FEHER APPD 4/13/95 J GILLESPIE APPD 4/13/95 R REINER PRODUCT SPEC -	AMP AMP Incorporated Harrisburg, PA 17105-3608
MATERIAL SEE TABLE	NAME TAB, FASTIN-FASTON, 6.35 [.250] SERIES	
FINISH SEE TABLE	DR 4/11/95 JR RUTH CHK 4/11/95 MS FEHER APPD 4/13/95 J GILLESPIE APPD 4/13/95 R REINER PRODUCT SPEC -	SIZE B
	APPLICATION SPEC -	CAGE CODE 00779
	WEIGHT -	DRAWING NO C-42241
		SCALE 4:1
		SHEET 1 OF 1

THIS DRAWING IS A CONTROLLED DOCUMENT FOR AMP INCORPORATED. IT IS SUBJECT TO CHANGE AND THE CONTROLLING ENGINEERING ORGANIZATION SHOULD BE CONTACTED FOR THE LATEST REVISION.